

November 11, 2002

NIOSH Docket Office via email
M/S C-34
4676 Columbia Parkway
Cincinnati, OH 45226

RE: Proposed NIOSH Certification Standard for APR CBRN
 Federal Register Notice May 31, 2002 (Vol.67, Number 105, pg. 38127-38128)

Dear Sir or Madam:

ISEA supports NIOSH in its effort to develop a standard for evaluating the effectiveness of respirators for use in atmospheres that may contain chemical, biological, radiological, and nuclear (CBRN) agents, and to certify respirators to that standard. We recognize that it is imperative that these user needs be addressed as soon as possible.

ISEA recognizes the improvement in the abbreviated process used to develop this standard over the SCBA CBRN standard. Further improvement could include formal responses to issues raised during the process and highlights of the changes made from revision to revision.

We encourage NIOSH to develop performance-based standards for equipment that will protect users and resist including design restrictive specifications in the standard. Design restrictive criteria inhibits innovation and impedes improvements.

Common Connector Issues

While the September 16, 2002 version of the APR CBRN concept does not mention interchangeability, the concept still specifies a common connector with several requirements for ensuring compatibility.

The following caution and limitation from the Concept suggests that interchanging the parts would violate the approval:

“Never substitute, modify, add, or omit parts. Use only exact replacement parts in the configuration as specified by the applicable regulations.”

However, the standard would still allow interchangeability to happen. In fact NIOSH presentations have indicated these CBRN standards will promote interchangeability.

ISEA believes specifying the connection and requirements for the canister as listed above does not necessarily ensure proper function even though they physically connect. The only way to ensure this is to test the facepiece and cartridge combination.

For at least 30 years (30 CFR 11 and 42 CFR 84, Subpart D Approval and Disapproval § 84.30) interchangeability has not been allowed and NIOSH has exclusively approved only complete respirator systems.

In fact, in 1984 NIOSH issued a User's Notice⁽¹⁾ on this subject stating "Several cases have been reported to NIOSH where unapproved modifications or use of an unapproved subassembly have resulted in respirator failures. Therefore, users of NIOSH/MSHA approved respirators are cautioned against interchanging subassemblies or making unapproved modifications to their respiratory protective devices." It also indicated "A user who modifies a certified respirator may not be able to determine whether a change will decrease respiratory protection." This points out all the more reason why these combinations need to be tested first before allowing interchangeability.

Systems Approval

Respirators are designed as a system. This includes the combined performance of the individual components, as well as the quality system of the individual manufacturer. Interchangeability should only be allowed when there is some testing to show the combination works.

For this reason ISEA recommends that the following wording be added to the cautions and limitations section of the approval label:

Caution/Limitation

This respirator is approved as a system using facemasks and canisters supplied and tested by the same manufacturer. Interchanging facemasks and canisters of different manufacturers is not permitted unless declared permissible by federal regulators during a federally declared terrorist emergency. Interchanging a respiratory protection component voids the NIOSH approval and could compromise the protection afforded to the user resulting in the risk death or serious injury.

Given the potentially dangerous environments these products may be used in, NIOSH should conduct a study that verifies that interchangeability using this common connector works, i.e. the product functions properly. This study should test a wide range of combinations of manufacturers CBRN approved products and validate the common connector concept. This would provide some confidence in proper operation when parts are interchanged while still allowing first responders to have interoperability to protect themselves in emergencies when supplies are affected. This approach would attempt to provide the same level of protection for first responders that are guaranteed for industrial users.

Surrogate Test Agents

For this second NIOSH proposed standard for equipment to protect against CBRN challenges, we must again strongly urge NIOSH to focus their effort on developing surrogate test agents. This would allow manufacturers of all PPE to test products in their labs prior to submitting

them for approval. It would also significantly reduce the cost of approval. This is an urgent need that is necessary for equipment development, testing, design and refinement.

Certification Tests

The full facepiece fogging test in section 6b is a new concept; fogging is not easily addressed or eliminated. This seems to be a very extensive, expensive, subjective test. NIOSH should consider a more routine steam generator and light transmission test.

Logistics

The current proposal involves 110 respirators and 116 additional canisters tests, some of which are 30 days in duration. The ISEA members are concerned with the costs and timeliness of approvals. Under the current process of accepting approval applications, there potentially could be several months between approvals for applications received on the same day. To prevent unfairness due to "the order that the mail is opened", ISEA recommends that approvals be held and released at the same time for all applications submitted within the same initial time period, e.g., the first 30 days after NIOSH begins accepting applications for approval. To further prevent delays, we recommend that NIOSH implement the use of the DEIMS (unproven submission software) implementation be delayed until after the CBRN standards are resolved.

Facepiece Resistance, Thread and Gasket Specifications, Lens Abrasion, and Permeation

Facepiece Resistance

We are concerned about the maximum facepiece resistance of 10mm because of inconsistency of test methods in measuring that resistance. We suspect that the 10mm facepiece resistance requirement has come from the military mask specifications. These specifications, however also describe a test apparatus, which measures facepiece resistance at the eye of the head form rather than in the oral nasal cavity. If the reading is done within the nose cup, the fit of that nose cup on the head form can affect the system level of resistance. Therefore, the method used to measure the resistance can have a significant effect on the result. In order to prevent such a problem, we recommend that the maximum resistance of the facepiece be increased to 15mm. The total system resistance would now be 70 mm, which is consistent with chest-mounted device requirements.

Thread and Gasket Specifications

Thread Design

Countless full-face respirators designed with a DIN style thread have been used for years in military and industrial applications. There are several existing standards with specifications for DIN threads. Simply adapting the EN 148-1 thread requirements as proposed by NIOSH would exclude many respirators designed for and used by the US Military and first responders. These respirators allow interchangeability of canisters and have a long history of successful field and laboratory performance. The comments below are based on a review of the following specifications:

- EN 148-1,
- NATO STANAG 4155, and
- Military Specification PD-EA-M-1801/E5-1-1054/D-1-1076.

Thread Specification Background

Each document specifies a thread and thread engagement length. Each of these specifications requires the thread to be a rolled thread RD 40 x 3.63 mm. However, the thread engagement length of the canister to respirator specification is different among these documents. The thread engagement length as used in these comments is the distance from the bottom of the gasket to the edge of the internal threads (see Figure 1). The internal threads are the female threads located on the respirator facepiece. The external threads are the (male) threads located on the canister.

Internal Thread

The specified thread in all three documents is RD 40 x 3.63 mm, but the internal thread depth on the facepiece specified in the Military Specification PD-EA-M-1801/E5-1-1054/D-1-1076 (Mil Spec) is shorter than what is required by EN 148-1 and NATO STANAG 4155. This was done to provide a lower profile full-face and faster canister attachment. It is important to note that this shorter internal thread is still compatible with the longer external thread of the EN 148-1. The internal thread height specification of EN 148-1 requires a thread engagement length (distance from bottom of gasket to edge) to be 15-16.5 mm, while the Mil Spec requires 8.75-9.25 mm.

Because the M40, MCU 2P and Millennium Gas military masks are compatible with the C2A1 military canister and EN 148-1 canisters, we suggest adapting the high end number (15-16.5 mm) for the internal thread from the EN 148-1 standard and the low end of the Mil Spec (8.75-9.25 mm) to make an internal thread length recommendation of 8.75-16.5 mm. Opening up the internal thread depth specification to accommodate both internal thread designs will allow existing US Military and First Responder respirator designs to be part of CBRN. This is shown in Figure 1.

External Thread

The NATO STANAG 4155 and EN 148.1 have a minimum external male thread run out of 16 mm, while the US Military Standard for the C2A1 minimum external male length is 15 mm. These minimum run out requirements are required to ensure the canister will seal with the gasket. Since the C2A1 canister is compatible with the EN 148-1 internal threads we recommend establishing the C2A1 minimum run out of 15 mm as the standard minimum run out for the APR CBRN standard. This is shown in Figure 2.

Gasket

In order to ensure a seal between the canister and full-face, a min/max gasket thickness is also required. To ensure that the C2A1 canister will be compatible with the EN 148-1 external threads a gasket of 1.5 mm is required. This is calculated by subtracting the minimum run out on the canister (15 mm) from the maximum internal thread height engagement (16.5 mm). The maximum thickness also needs to be established to ensure enough thread engagement. The maximum gasket thickness is 2.5 mm. That is currently the maximum thickness according to EN 148.1.

Based on the above information, ISEA recommends the following regarding thread design:

Parameter	Requirement (mm)
Internal Thread – Thread Engagement Length	8.75 – 16.5 mm
External Thread – Run Out Length	15 mm
Gasket Thickness (minimum / maximum)	1.5 mm / 2.5 mm

This not only allows a common connector in the NIOSH APR CBRN standard, but also makes it possible for existing military and first responder masks to be tested to the new standard.

Gasket Materials

Under section 4.3.2 of the September 16, 2002 concept paper it states, “the gasket material shall be ethylene propylene diene monomer, EPDM, with a hardness of 65 ± 10 shore A durometer at room temperature.” Specifying the gasket material precludes the use of other materials cited in the literature and documented by the military that provide acceptable permeation resistance, e.g. butyl rubber, and may provide other benefits. These materials with proven agent permeation resistance should not be excluded as potential gasket materials.

ISEA recommends that the standard state, “the gasket material shall be EPDM or an alternative whose agent permeation properties are equal to, or better than EPDM.” The manufacturer could be asked to supply documented evidence for their choice of material. The fact that the outer skin of the M40 and the FM12 from Avon are made from butyl rubber should be evidence that materials other than EPDM may be suitable as gasket materials.

Lens Abrasion

NIOSH has incorporated an NFPA Lens Abrasion test into the standard covering Gas Masks. The NFPA Test was developed due to the extremely hostile environments in which SCBA are repeatedly used in the fire service. The original premise was that lenses were being badly damaged during use causing visibility issues with the wearer. The application described was that the user would clean the lens with a gloved hand covered in debris from the fire scene causing scratching. The coatings for these lenses were also developed to withstand extreme heat and flames. A gas mask however will likely be used as a semi-disposable device that would probably be discarded after a single use.

We understand that the purpose of the test is to ensure adequate visibility through the facepiece visor after extended storage, possibly in an environment such as the trunk of a vehicle. However, we do not believe that the test is representative of use of this class of device and would limit the facepiece to those only using a coated polycarbonate visor. Additionally, the application of the super hard coatings to lenses would add significant cost to these devices.

We recommend that a more use appropriate test method be employed such as the Oscillating Sand Method, which is described in MS 55799 for military gas masks.

Permeation Test

ISEA recommends that NIOSH give ample consideration to establishing permeation criteria for full ensemble gear, given the potential risk for dermal exposure in addition to respiratory risks.

If NIOSH continues to focus on permeation for respiratory protective devices only, we recommend that the permeation tests be done at the proposed concentrations but for duration of 6 hours rather than 12 hours. We do not feel that the duration of the test should be twice as long as for a SCBA test for CBRN approval.

There are not defined decontamination procedures that would allow an exposed user to exit a contaminated area, decontaminate the facepiece, change the filter canisters and re-enter using the same facepiece.

We are unaware of any work environment that requires a user to wear a respirator for 12 hours, nor would recommend such use without a clear understanding of the physical stresses involved. Due to these unknown stresses, a more responsible recommendation would be a four-hour work shift, thus allowing scene command and control an opportunity to ascertain the physical and mental well being of the responder. Therefore, a 6-hour permeation test at the recommended concentrations would be a more realistic test for this equipment and would not compromise the responsibility that we have to the responder community.

Thank you for your consideration.

Respectfully Submitted,

Janice C. Bradley, CSP
Technical Director

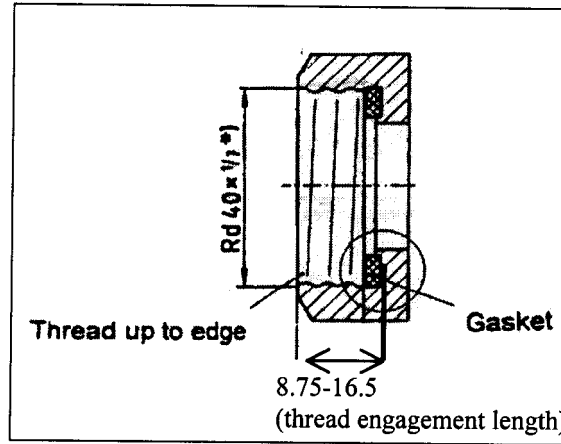

Figure 1: Internal Thread

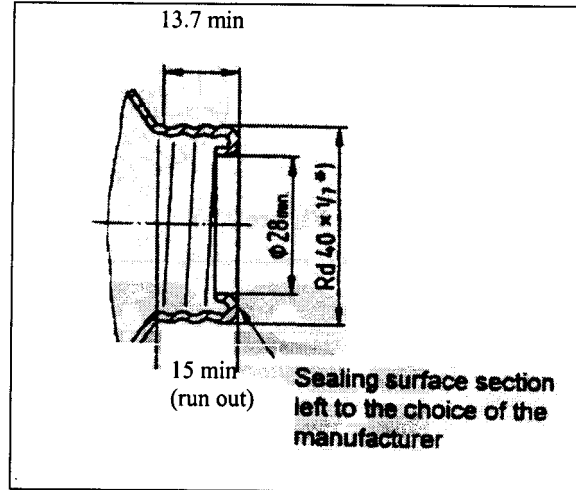

Figure 2: External Thread